

# CLAMPBRO®

## WOODWORKER



10" (250MM) TABLE SAW

MODEL NO: CTS17

PART NO: 6500752

### OPERATION & MAINTENANCE INSTRUCTIONS



ORIGINAL INSTRUCTIONS

GC0322

---

## INTRODUCTION

---

Thank you for purchasing this CLARKE product. This table saw has been designed to perform the sawing operation of ripping, cross-cutting, bevelling and mitering wood and wood products. This unit is designed for use with an 10" (250mm) carbide tipped blade.

Before attempting to use this product, please read this manual thoroughly and follow the instructions carefully. In doing so you will ensure the safety of yourself and that of others around you, and you can look forward to your purchase giving you long and satisfactory service.

---

## SPECIFICATIONS

---

Model	CTS17
Voltage	230V - 50 Hz
Power input	2000 W
No-load speed	4800 rpm
Ingress protection (IP) rating	IPX0
Table size	643 mm x 546 mm (ex extension)
Dust Extractor connector	34.9 (internal) / 39.5 mm (external)
Blade size:	Outside Diameter 250 mm
	Bore Diameter 30 mm
	Thickness 2.8 mm
	Number of teeth 24 TCT
Maximum cut depth @ 90 Degrees	72 mm
Maximum cut depth @ 45 Degrees	50 mm
Machine weight:	22 kg
Machine size (L x W x H)	695 x 917 x 1030mm (max)
Sound pressure level LpA	93.7 dB (A)
Guaranteed sound power level LWA:	106.7 dB (A)

This saw is NOT suitable for cutting:

- Timber greater than 70mm
- Metal, stone, rubber, plastic etc
- Logs or round timber

---

## **GUARANTEE**

---

This product is guaranteed against faulty manufacture for a period of 12 months from the date of purchase. Please keep your receipt which will be required as proof of purchase.

This guarantee is invalid if the product is found to have been abused or tampered with in any way, or not used for the purpose for which it was intended. Faulty goods should be returned to their place of purchase, no product can be returned to us without prior permission.

This guarantee does not effect your statutory rights.

---

## **ENVIRONMENTAL RECYCLING POLICY**

---









By purchasing this product, the customer is taking on the obligation to deal with its safe disposal in accordance with the Waste Electrical and Electronic Equipment (WEEE).

In effect, this means that this product must not be disposed of with general household waste. It must be disposed of according to the laws governing Waste Electrical and Electronic Equipment (WEEE) at a recognised disposal facility.

If disposing of this product or any damaged components, do not dispose of with general waste. This product contains valuable raw materials. Metal products should be taken to your local civic amenity site for recycling of metal products.

## SAFETY SYMBOLS

	Read instruction manual before use		Wear dust mask
	Wear safety glasses		Wear ear defenders
	Indoor Use Only		Danger of cut hand injury. Ensure guards are in place.

The above safety symbols appear on the product.

## SAFETY WARNINGS



CAUTION: DO NOT LET FAMILIARITY WITH YOUR TABLE SAW MAKE YOU CARELESS. REMEMBER THAT A CARELESS FRACTION OF A SECOND IS SUFFICIENT TO CAUSE SEVERE INJURY.

## PERMITTED USAGE

The table saw is constructed exclusively for the sawing of wood. The appropriate saw blade should be fitted according to the wood type (solid wood, chipboard or plywood).

- Read and understand the entire owner's manual before attempting assembly or operation.
- Read and understand the warnings posted on the machine and in this manual. Failure to comply with all of these warnings may cause serious injury.

## HEALTH

When sawing, dust particles will be produced which in some instances can be harmful (e.g. lead from old gloss paint, arsenic and chromium from chemically treated lumber).

To reduce the risk you should:

- Work in a well-ventilated area.
- Work with approved safety equipment such as dust masks that are specially designed to filter microscopic particles.
- If possible use/connect to a suitable dust extractor.

## GENERAL

1. **DO NOT** expose the saw to rain.
2. **DO NOT** use the saw in damp or wet conditions.
3. Keep the work area well lit.
4. **DO NOT** use the saw in the presence of flammable liquids and gases.
5. Remove loose items and unnecessary work pieces from the area before starting the saw.
6. Clean out sawdust from the interior of the saw to prevent a potential fire hazard. Attach a vacuum cleaner to the dust port for additional sawdust removal.
7. Wear ear protectors (plugs or muffs) during extended periods of operation.
8. Wear safety glasses. Everyday eyeglasses are not suitable as safety glasses.
9. Wear a dust mask when sawing wood.
10. **NEVER** wear gloves during operation.
11. Before operating this table saw, remove any neck tie, rings, watches and other jewellery and roll sleeves up past the elbows. Remove all loose clothing and confine long hair. Non-slip footwear or anti-skid floor strips are recommended.
12. Make sure that the machine stands stable on a firm, flat surface.
13. Before use, carefully check the saw and mains cable for damage or any other condition that may affect its operation. **DO NOT** use the saw if any part is damaged or defective.
14. **DO NOT** use the saw if the switch does not turn it on and off.
15. Remove keys and wrenches. Ensure that keys and wrenches are removed from the saw before turning it on following blade replacement.
16. Use the right tool for the task - **DO NOT** force small tools to do the job of a heavy duty tool. It will do the job better and safer at the rate for which it was intended. **DO NOT** use tools for purposes not intended; for example **DO NOT** use table saws to cut tree limbs or logs.
17. The use of any accessory or attachment other than one recommended in this instruction manual may present a risk of personal injury.
18. Connect table saws to a dust-collecting device when sawing wood.

19. Guard against electric shock - Avoid body contact with earthed or grounded surfaces.
20. Extension cables - Before use, inspect the extension cable and replace if damaged.
21. Avoid unintentional starting. Make sure the switch is in the OFF position before connecting the machine to the power supply.
22. **DO NOT** abuse the cable. Never yank the cable to disconnect it from the mains supply. Keep the cable away from heat, oil, water and sharp edges.
23. This table saw is designed and intended for use by properly trained and experienced personnel only. If you are not familiar with the proper and safe operation of a table saw, **DO NOT** use until proper training and knowledge have been obtained.
24. Stay alert, watch what you are doing. Use common sense. **DO NOT** operate the saw when you are tired or under the influence of drugs, alcohol or any medication.
25. Keep hands clear of the saw blade.
26. Maintain a balanced stance at all times so that you do not fall on to the blade. **DO NOT** overreach or use excessive force to perform any operation.
27. Use push-sticks or push blocks to feed the workpiece past the saw blade. Keep your hands and fingers well away from the blade.
28. The push-stick should always be stored with the machine when not in use.
29. Pay particular attention to instructions on reducing risk of kickback on page 9.
30. **NEVER** perform any operation freehand, which means using only your hands to support or guide the workpiece. Always use either the fence or the mitre fence to position and guide the work.



**WARNING: FREEHAND CUTTING IS THE MAJOR CAUSE OF KICKBACK AND FINGER AMPUTATIONS.**

---

31. Give your work undivided attention. Looking around, carrying on a conversation and "horse-play" are careless acts that can result in serious injury.
32. When not in use, store the saw in a dry place out of reach of children and animals.
33. Replace the warning labels if they become obscured or removed.

34. Turn off and unplug the saw before cleaning. Use a brush or compressed air to remove chips or debris — **DO NOT** use your hands. Eye protection should be used when using compressed air.
35. Disconnect the saw from the mains supply before changing blades or carrying out maintenance.
36. Keep blades sharp and clean for better and safer performance. Inspect power cables periodically and if damaged have them repaired.
37. Repairs should only be carried out by qualified persons using original spare parts, otherwise this may result in considerable danger to the user.
38. Keep handles dry, clean and free from oil and grease.
39. Unplug the saw - switch off and wait for the blade to come to a complete standstill before leaving it unattended.

### **ADDITIONAL SAFETY RULES FOR TABLE SAWS**

1. The thickness of the saw blade must be greater than the thickness of the riving knife.
2. **DO NOT** stand on the table saw.
3. During transportation make sure that the upper part of the saw blade is covered by the guard.
4. **DO NOT** use the guard for handling or transportation.
5. Check that the workpiece is properly supported. Always provide additional support for long workpieces.
6. **DO NOT** exert side pressure on the saw blade.
7. Make sure that the blade rotates in the correct direction and that the teeth are pointing to the front of the saw.
8. **DO NOT** apply lubricants to the blade when it is running.
9. **NEVER** reach around or over the saw blade. **NEVER** reach for a workpiece until the saw blade has completely stopped.
10. Make sure that the blade and retaining discs are clean. Tighten the retaining screw securely.
11. Keep the saw blade sharp.
12. Make sure that the riving knife is adjusted to the correct distance from the blade.
13. **NEVER** operate the saw without the guard in place.
14. **DO NOT** use abrasive discs or diamond cutting wheels.
15. Rebating, slotting or grooving is not allowed.

16. **DO NOT** use a moulding head cutter with this saw.
17. Remove the rip fence when crosscutting. **NEVER** use the rip fence as a cut-off gauge when crosscutting.
18. Knock out any loose knots from the workpiece before you begin to cut.
19. Provide adequate support to the rear and the sides of the saw table for long or wide workpieces.
20. **NEVER** leave the saw running unattended. Turn the power off and **DO NOT** leave the saw until it comes to a complete stop.
21. Before using the saw on an actual workpiece, let it run for a few moments. Watch for vibration or wobbling that could indicate poor installation or a poorly balanced blade.
22. **ALWAYS** hold work firmly against the mitre gauge or rip fence.
23. **NEVER** stand or have any part of your body in line with the path of the saw blade. keep your hands out of the saw blade path.
24. Feed work into the blade against the direction of rotation only.
25. **NEVER** attempt to free a stalled saw blade without first turning the saw off. Turn the power switch off immediately to prevent motor damage.
26. Avoid awkward operations and hand positions where a sudden slip could cause your hand to move into the saw blade.
27. Avoid abrupt, fast feeding. Feed as slowly as possible when cutting hard workpieces. **DO NOT** bend or twist the workpiece while feeding. If you stall or jam the blade in the workpiece, turn the table saw off immediately. Unplug the saw, then clear the jam.
28. **NEVER** remove cut-off pieces near the blade or touch the blade guard while the blade is running.

## SAW BLADES

1. The maximum speed of the saw blade must always be equal to or greater than the no-load speed of the table saw as specified on the rating plate.
2. Only use saw blades recommended by the manufacturer and which are the exact bore and diameter required for this machine. **DO NOT** use any spacers to make a blade fit onto the spindle. Use only the blades specified in this manual.
3. Clean the spindle, retaining discs (especially the installing surface) and retaining bolt before installing the blade. Poor installation may cause vibration/wobbling or slippage of the blade.
4. **DO NOT** use saw blades which are damaged or deformed.



5. Take care that the selection of the saw blade is suitable for the material to be cut.
6. Make sure the blade is not contacting the riving knife or workpiece before the switch is turned on.
7. Wear gloves when handling saw blades and rough material. Saw blades shall be carried in a holder whenever practicable. Take care that gloves can catch on rotating blades.

## **KICKBACK**

Kickback is a sudden reaction to a pinched, bound or misaligned saw blade, it causes the workpiece to be ejected from the tool back towards the operator. Kickbacks can lead to serious personal injury.

You can avoid kickbacks by:

- a. Keeping the blade sharp,
- b. Keeping the rip fence parallel to the blade,
- c. Keeping the riving knife and blade guard in place and operating properly,
- d. Not releasing the workpiece until you have pushed it all the way past the blade,
- e. Not ripping a workpiece that is twisted or warped or does not have a straight edge to guide along the fence.

If you do not have a clear understanding of kickback and how it occurs, **DO NOT** use the table saw.

## **REMAINING HAZARDS**

The machine has been built in accordance with recognized safety standards but some remaining hazards may still exist.

These can be minimized by following the instructions in the operating manual.

## ELECTRICAL CONNECTIONS



**WARNING! READ THESE ELECTRICAL SAFETY INSTRUCTIONS THOROUGHLY BEFORE CONNECTING THE PRODUCT TO THE MAINS SUPPLY.**

Before switching the product on, make sure that the voltage of your electricity supply is the same as that indicated on the rating plate. This product is designed to operate on 230VAC 50Hz. Connecting it to any other power source may cause damage.

This product may be fitted with a non-rewireable plug. If it is necessary to change the fuse in the plug, the fuse cover must be refitted. If the fuse cover becomes lost or damaged, the plug must not be used until a suitable replacement is obtained.

If the plug has to be changed because it is not suitable for your socket, or due to damage, it should be cut off and a replacement fitted, following the wiring instructions shown below. The old plug must be disposed of safely, as insertion into a mains socket could cause an electrical hazard.



**WARNING: THE WIRES IN THE POWER CABLE OF THIS PRODUCT ARE COLOURED IN ACCORDANCE WITH THE FOLLOWING CODE:  
BLUE = NEUTRAL    BROWN = LIVE**

If the colours of the wires in the power cable of this product do not correspond with the markings on the terminals of your plug, proceed as follows.

- The **Blue** wire must be connected to the terminal marked **N** or coloured **Black**.
- The **Brown** wire must be connected to the terminal marked **L** or coloured **Red**

**Plug must be BS1363/A approved.**

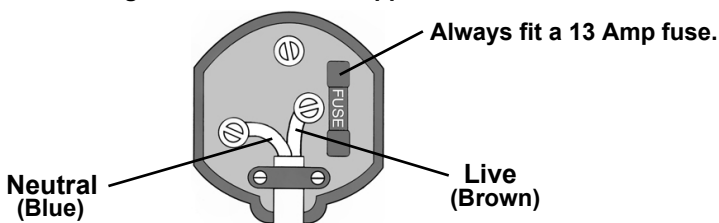

**Ensure that the outer sheath of the cable is firmly held by the clamp**

We strongly recommend that this machine is connected to the mains supply via a Residual Current Device (RCD)

If in any doubt, consult a qualified electrician. DO NOT attempt any repairs yourself.



**This symbol indicates that this is a Class II product and does not require an earth connection.**

## COMPONENT OVERVIEW

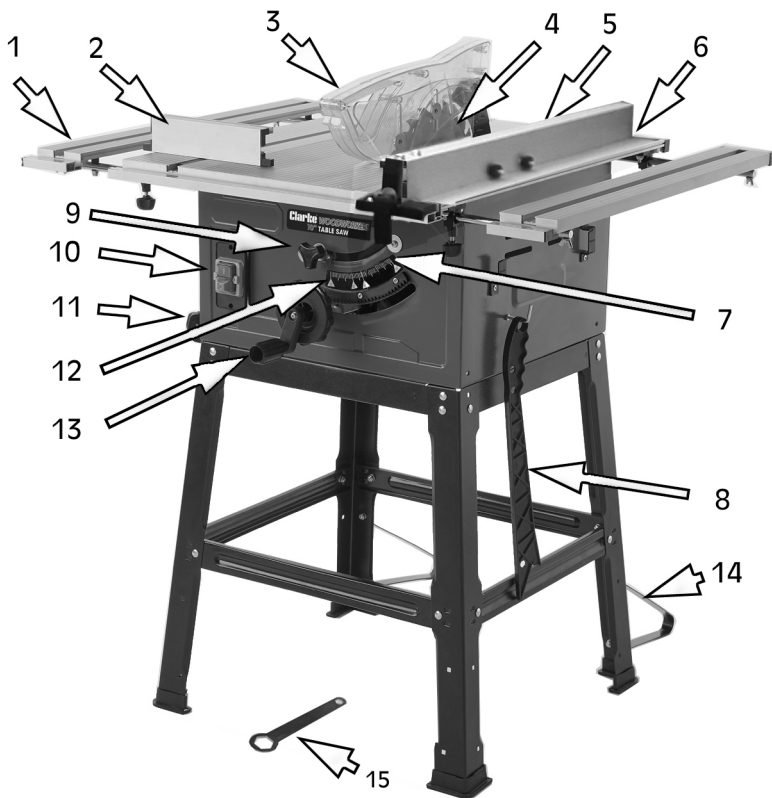

1	Table extension	9	Tilt adjusting knob
2	Mitre square assembly	10	On/Off switch
3	Blade Guard	11	Dust extract duct
4	Blade	12	Tilt angle scale
5	Parallel Guide Fence assembly	13	Height adjusting handle
6	Work table	14	Stand stabilisers
7	Fence securing handle/clamp	15	Blade removal wrench & key
8	Push stick		

## ASSEMBLY

The following items should be supplied in the carton. If any parts are missing, do not use your table saw until the missing parts are obtained.

Table Saw	Fixings Pack
Parallel Guide Fence assembly	Push Stick
Mitre Guide/fence	10" TCT Blade (fitted)
Blade Guard Assembly	Hex key
Sliding table extension x 2	Ring spanners (large & small)
Stand components: 4 x legs 4 x Upper crossbars 4 x Lower crossbars 4 x Rubber feet 2 x Stand stabilisers	

### ASSEMBLING THE STAND

**NOTE:** The table saw can be operated without the stand if required.

1. Assemble the stand as shown by joining the cross members to the legs using the bolts, flat washers, spring washers and nuts supplied.
  - The long cross members are fitted nearer to the feet.

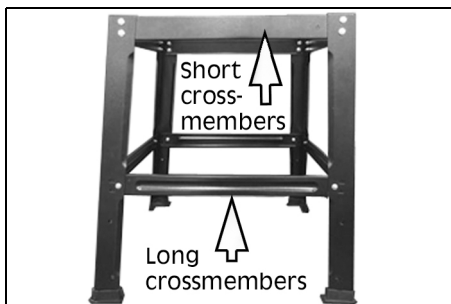

2. Fit the rubber feet to the legs.

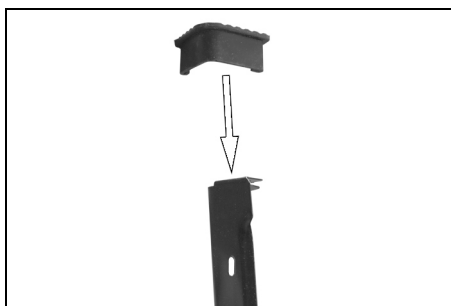

3. Attach the stabilisers to the rear legs using the bolts, washers and nuts supplied.
4. Check that all bolts are tightened and then turn the table saw and stand over onto the feet.
5. Fit the table saw to the stand. Secure the assemblies together by bolting the stand to the base of the machine.

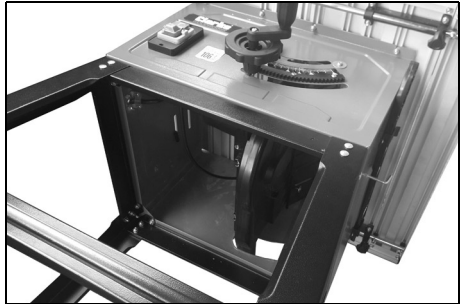

## FITTING THE TABLE EXTENSION

Fit the table extensions by slackening the wingnuts on each support arm and sliding both the rods into the brackets under the table top.

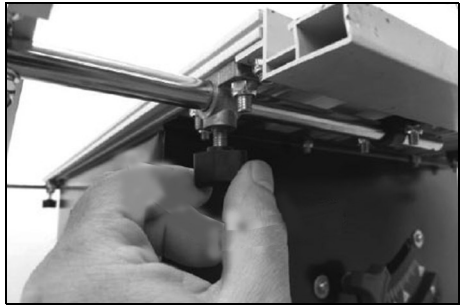

Slide the table extension to the required position and tighten the knobs to secure.

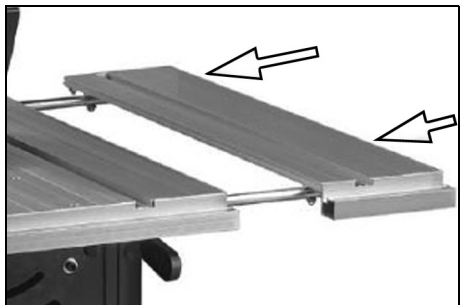

## FITTING THE BLADE GUARD

1. With the blade and riving knife fitted, fit the blade guard to the riving knife. Engage the socket in the guard with the slot in the riving knife and tighten the screw/ locknut to pinch it to the knife ensuring it can still move up and down in use.

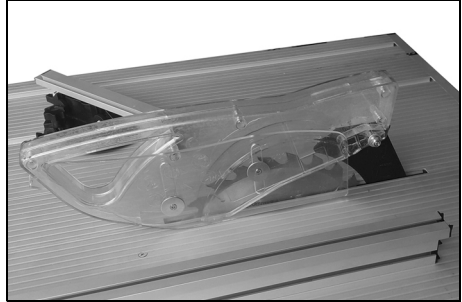

## FITTING THE MITRE ASSEMBLY

1. Fit the fence to the mitre angle attachment and secure with the two thumbscrews. Slide the heads of the bolts into the channel in the fence and attach the thumb nuts.
2. Slide the mitre attachment into the groove in the table top.

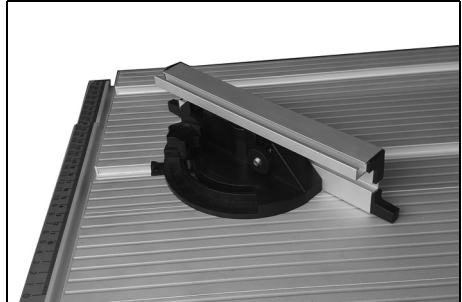

## FITTING THE PARALLEL FENCE

The parallel fence is essential to ensure straight line cutting and should always be used when rip sawing.

The parallel fence can be mounted on either side of the table. If you change the side you will need to fit the fence the other way round.

1. Engage the parallel fence over the ends of the table.
2. Use the scale on the table to set the parallel fence to the required distance from the blade.
3. Lock the parallel fence in the required position by tightening the locking handle at the end.



The fence may be set at any suitable position on the table to either left or right of the saw blade.

- Measurement scales (in mm) are provided at the front and back of the table. These may be used to position the rip fence for rough cutting. If precision is required, use a ruler between the rip fence and the front and back of the blade.

## CONNECTING THE DUST EXTRACT

This table saw is equipped with a dust extraction port. For safe operation, we recommend that a suitable dust extraction device or vacuum cleaner is connected during operation.



**WARNING: EXCESSIVE SAWDUST BUILD UP AROUND THE MOTOR COULD POSSIBLY IGNITE AND CAUSE DAMAGE TO THE MOTOR, TABLE SAW OR YOUR WORKSHOP.**

---

---

# OPERATION

---



CAUTION: BEFORE STARTING UP THE SAW ALWAYS CHECK THE FOLLOWING POINTS:

1. Is the saw blade firmly tightened and can the blade rotate freely?
2. Are all the locking levers firmly locked?
3. Is the riving knife aligned with the saw blade?
4. Is the blade guard fitted?
5. Make sure that the fences are not touching the blade.
6. Are there any wood pieces jammed between the saw blade and the table?
7. Have all loose workpieces been removed from the table?
8. Have all the setting tools been removed?
9. Wear protective goggles, ear protection and dust mask.

---

## BEFORE STARTING WORK

All covers including the blade cover guard and side cover must be properly fitted before switching on.

When working with wood that has been used before, take care to remove all foreign bodies such as nails or screws etc before cutting.

Always stand the table saw on a flat and firm surface.

## USE OF THE ON/OFF SWITCH

1. To turn the saw on, press the green button "I".
  - Wait for the blade to reach its maximum speed before making the cut.
2. To turn the saw off again, press the red button "0".

**NOTE:** The blade will spin for several seconds after the machine is switched off.

**NOTE:** The guard must always be lowered over the workpiece before you begin to cut.

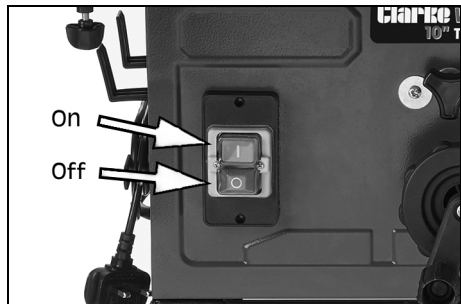



## ADJUSTMENTS

After every new adjustment, we recommend you to make a trial cut in order to check the new settings.

### PARALLEL FENCE

The parallel fence can be mounted on either side of the table. If you change the side you will need to fit the fence the other way round.

1. Engage the parallel fence over the ends of the table.
2. Use the scale on the table to set the parallel fence to the required distance from the blade.
3. Lock the parallel fence in the required position by tightening the locking handle at the end.

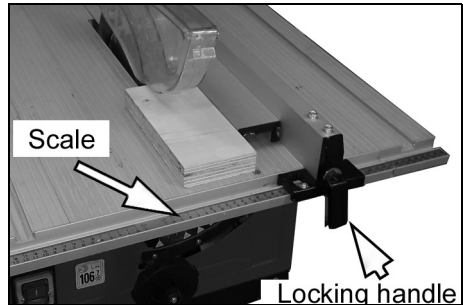

### MITRE GAUGE

1. Insert the guide bar into the groove in the table top.
2. Loosen the knob to set the angle required.
3. Rotate until the pointer points to the angle on the scale you want.
4. Retighten the knob.
  - If required you can remove the fence from the mitre assembly using the 2 locking knobs, or slide it in either direction to suit the task before re-tightening.

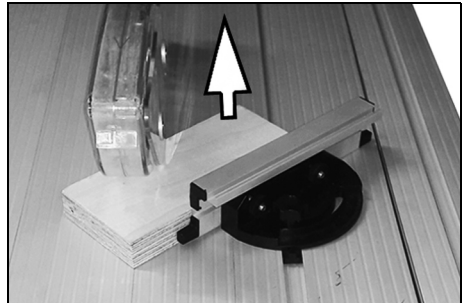

### SETTING THE BLADE ANGLE

1. Release the bevel locking handle.
2. Tilt the saw blade and motor assembly until the saw blade is at the desired angle.
3. Tighten the bevel lock to lock the blade at the required angle shown on the scale.

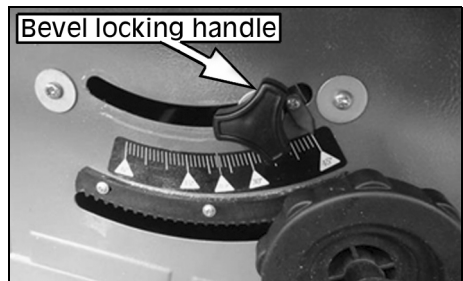

---

## CUTTING TIPS

---

### RIPPING CUTS & CROSS CUTS

Ripping is when you use the saw to cut along the grain of the wood.

The parallel fence must always be used when making ripping cuts.

1. Press one edge of the workpiece against the parallel fence while the flat side lies on the saw table.
  - The blade guard must always be lowered over the workpiece and blade.
  - When you make a ripping cut, never stand in line with the blade.
2. Set the parallel fence in accordance with the desired width.
3. Switch on the saw.
4. Place your hands (with fingers closed) flat on the workpiece and push the workpiece along the parallel fence towards the blade.
5. Guide at the side with your left or right hand (depending on the position of the parallel fence) only as far as the front edge of the guard hood.
6. Always push the workpiece through to the end of the riving knife using a push stick.
7. Do not remove the offcut piece until the blade has stopped spinning.
8. Secure long workpieces against falling off at the end of the cut (e.g. with a roller stand etc).

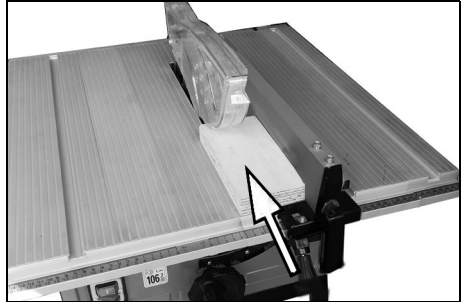

### CUTTING NARROW WORKPIECES

Always use a push stick when the workpiece is narrow and for holding the workpiece flat on the table.

- Take extra care to keep your thumbs away from the saw blade when feeding the workpiece past the blade.

When not in use, store the push stick in its holder on the side of the machine.

Replace a damaged push stick immediately.

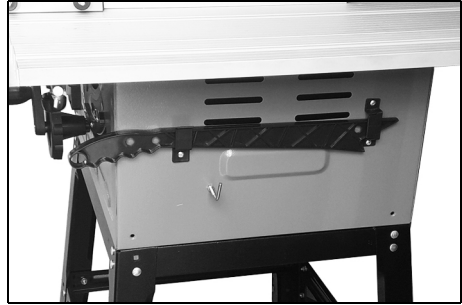

## MITRE CUTS

1. Slide the mitre gauge into the groove in the table.
2. Adjust the mitre gauge to the required angle.
3. Press the workpiece firmly against the mitre gauge.
4. Switch on the saw.
5. Push the mitre gauge and the workpiece toward the blade to make the cut.

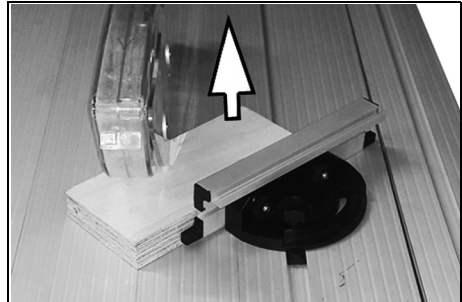

**IMPORTANT:** Always hold the guided part of the workpiece. Never hold the part which is to be cut off.

6. Push the mitre gauge forward until the workpiece is cut all the way through.
7. Switch off and do not remove the offcut until the blade has stopped.

## BEVEL CUTS

Bevel cuts must always be made using the parallel fence.

1. Undo the bevel lock handle and set the saw to the desired angle on the scale.
2. Tighten the bevel handle to lock the blade at the selected angle.
3. Set the parallel fence.
4. Perform the cut as you would for a ripping cut.

**NOTE:** If precision is required, use a protractor between the blade and table.

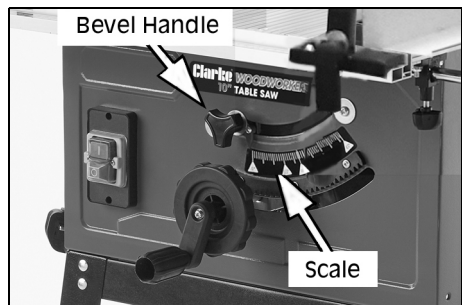

---

# MAINTENANCE

---



**WARNING: REMOVE THE PLUG FROM THE MAINS POWER SUPPLY BEFORE CARRYING OUT ANY ADJUSTMENT OR MAINTENANCE.**

---

Your saw has been designed to operate over a long period of time with a minimum of maintenance. Continuous satisfactory operation depends upon proper tool care and regular cleaning.

Never use caustic agents to clean plastic parts.

1. Remove dust regularly from the machine. Cleaning is best carried out with a fine brush.
2. Regularly clean the table top.
3. Regularly clean the dust collection outlet.
4. Use a half-round file where necessary to keep the teeth sharp. A blade that is badly dulled or with damaged teeth should be replaced immediately.

## CHANGING THE BLADE



**WARNING: WEAR SAFETY GLOVES WHEN CHANGING THE SAW BLADE.**

**WARNING: THE REPLACEMENT BLADE MUST BE RATED TO AT LEAST 7000 RPM.**

1. Remove the transparent blade guard.
2. Remove the table cover panel by unscrewing the three securing screws.
  - The edge furthest from the blade has a tongue and groove joint with the table top.

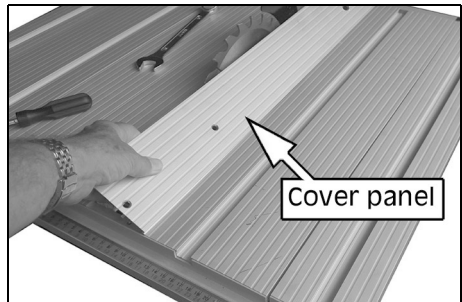

3. Using the open spanner and hex key provided, hold the spindle to prevent the motor from turning and undo the saw blade securing nut (normal thread).
4. Remove the outer retaining disc followed by the saw blade by lifting it clear of the motor shaft and carefully withdrawing it from above.

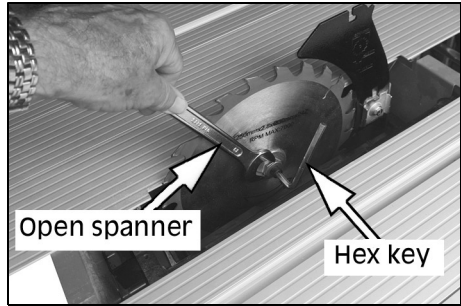

5. Replace in reverse order ensuring the saw blade teeth face downwards at the front of the table.
  - The arrow on the face of the blade will show the rotation to be anticlockwise.
6. Hold the blade firmly when tightening the centre nut, taking care to avoid injuring your hand on the sharp teeth.

***IMPORTANT: Note the running direction. The cutting angle of the teeth must point in the running direction, i.e. forwards (see arrow on the blade guard).***

7. Check that the riving knife lines up with the saw blade.
8. Refit the table insert and the transparent blade guard.
9. Check that all components are properly mounted and in good working condition before you begin working with the saw again.

## TROUBLE SHOOTING

Problem	Probable cause	Solution
Saw will not start	<ol style="list-style-type: none"> <li>1. Saw not plugged in</li> <li>2. Fuse blown</li> <li>3. Power cable damaged</li> </ol>	<ol style="list-style-type: none"> <li>1. Plug in the machine</li> <li>2. Replace fuse</li> <li>3. Have cable replaced by your dealer.</li> </ol>
Does not make accurate 45° and 90° cuts	<ol style="list-style-type: none"> <li>1. Table adjuster not set correctly</li> </ol>	<ol style="list-style-type: none"> <li>1. Check blade with a set square and adjust pointer to zero.</li> </ol>
Material pinches blade	<ol style="list-style-type: none"> <li>1. Fence not aligned with blade. <ul style="list-style-type: none"> <li>• Warped wood.</li> <li>• Edge not set square to fence.</li> </ul> </li> </ol>	<ol style="list-style-type: none"> <li>1. Check and adjust fence. Select another piece of wood.</li> <li>2. Select another piece of wood.</li> </ol>
Material binds on the riving knife	<ol style="list-style-type: none"> <li>1. Riving knife not aligned correctly</li> </ol>	<ol style="list-style-type: none"> <li>1. Check that riving knife is correctly aligned with blade</li> </ol>
Saw makes unsatisfactory cuts	<ol style="list-style-type: none"> <li>1. Dull blade</li> <li>2. Blade mounted backwards</li> <li>3. Gum or pitch on blade</li>   <li>4. Incorrect blade for work</li> <li>5. Gum or pitch on table causing erratic feed</li> </ol>	<ol style="list-style-type: none"> <li>1. Replace blade</li> <li>2. Turn blade around</li> <li>3. Remove blade and clean with turpentine and coarse steel wool</li> <li>4. Change the blade</li> <li>5. Clean table with turpentine and steel wool and apply wax</li> </ol>
Material kicked back from blade slot	<ol style="list-style-type: none"> <li>1. Rip fence out of alignment</li> <li>2. Riving knife not aligned with blade</li> <li>3. Feeding stock without rip fence</li> <li>4. Riving knife not in place</li>   <li>5. Letting go of wood before it is all the way past the saw blade</li> <li>6. Dull blade</li> </ol>	<ol style="list-style-type: none"> <li>1. Align rip fence with blade</li> <li>2. Align riving knife with blade</li> <li>3. Install and use rip fence</li>   <li>4. Install and use riving knife with guard</li> <li>5. Push work fully past blade before releasing work</li> <li>6. Replace blade</li> </ol>
Blade does not tilt freely	<ol style="list-style-type: none"> <li>1. Sawdust in tilting mechanism</li> </ol>	<ol style="list-style-type: none"> <li>1. Brush or blow out loose dust</li> </ol>
Blade does not come up to speed	<ol style="list-style-type: none"> <li>1. Extension cable too long</li> </ol>	<ol style="list-style-type: none"> <li>1. Replace or use shorter cable</li> </ol>
Machine vibrates	<ol style="list-style-type: none"> <li>1. Saw not standing securely on bench</li> <li>2. Damaged saw blade</li> </ol>	<ol style="list-style-type: none"> <li>1. Reposition on flat level surface</li> <li>2. Replace blade.</li> </ol>

# DECLARATIONS OF CONFORMITY



Fitzwilliam Hall, Fitzwilliam Place, Dublin 2

## DECLARATION OF CONFORMITY

This is an important document and should be retained.

We hereby declare that this product(s) complies with the following directive(s):  
 2006/42/EC Machinery Directive  
 2014/30/EU Electromagnetic Compatibility Directive  
 2011/65/EU Restriction of Hazardous substances (2011/65/EU/ RoHS Amendment)

The following standards have been applied to the product(s):  
 EN 62841-3-1-1:2014/A11:2017, EN 55014-1:2017, EN 55014-2:2015,  
 EN 55014-1:2006/A2:2011, EN 61000-3-2:2014, EN 61000-3-11:2000, EN 62321-1:2013,  
 EN 62321-2:2014, EN 62321-3-1:2014, EN 62321-4:2014, EN 62321-5:2014, EN 62321-6:2015,  
 EN 62321-7:2015, EN 62321-8:2017.

The technical documentation required to demonstrate that the product(s) meet(s) the requirement(s) of the aforementioned directive(s) has been compiled and is available for inspection by the relevant enforcement authorities.

The CE mark was first applied in: 2021

Product Description: 250mm Table Saw  
 Model number(s): CTS17  
 Serial / batch Number: N/A  
 Date of Issue: 09/07/2021

Signed:   
 J.A. Clarke  
 Director



Hemmill Street, Epping, Essex CM16 4LG

## DECLARATION OF CONFORMITY

This is an important document and should be retained.

We hereby declare that this product(s) complies with the following statutory requirement(s):  
 Supply of Machinery (Safety) Regulations 2008  
 Electromagnetic Compatibility Regulations 2016  
 The Restriction of the Use of Certain Hazardous Substances in Electrical and Electronic Equipment Regulations 2012

The following standards have been applied to the product(s):  
 EN 62841-3-1-1:2014/A11:2017, EN 55014-1:2017, EN 55014-2:2015,  
 EN 55014-1:2006/A2:2011, EN 61000-3-2:2014, EN 61000-3-11:2000, EN 62321-1:2013,  
 EN 62321-2:2014, EN 62321-3-1:2014, EN 62321-4:2014, EN 62321-5:2014, EN 62321-6:2015,  
 EN 62321-7:2015, EN 62321-8:2017.

The technical documentation required to demonstrate that the product(s) meet(s) the requirement(s) of the aforementioned legislation has been compiled and is available for inspection by the relevant enforcement authorities.

The UKCA mark was first applied in: 2021

Product Description: 250mm Table Saw  
 Model number(s): CTS17  
 Serial / batch Number: N/A  
 Date of Issue: 09/07/2021

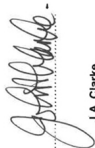
Signed:   
 J.A. Clarke  
 Director

# PARTS DIAGRAM

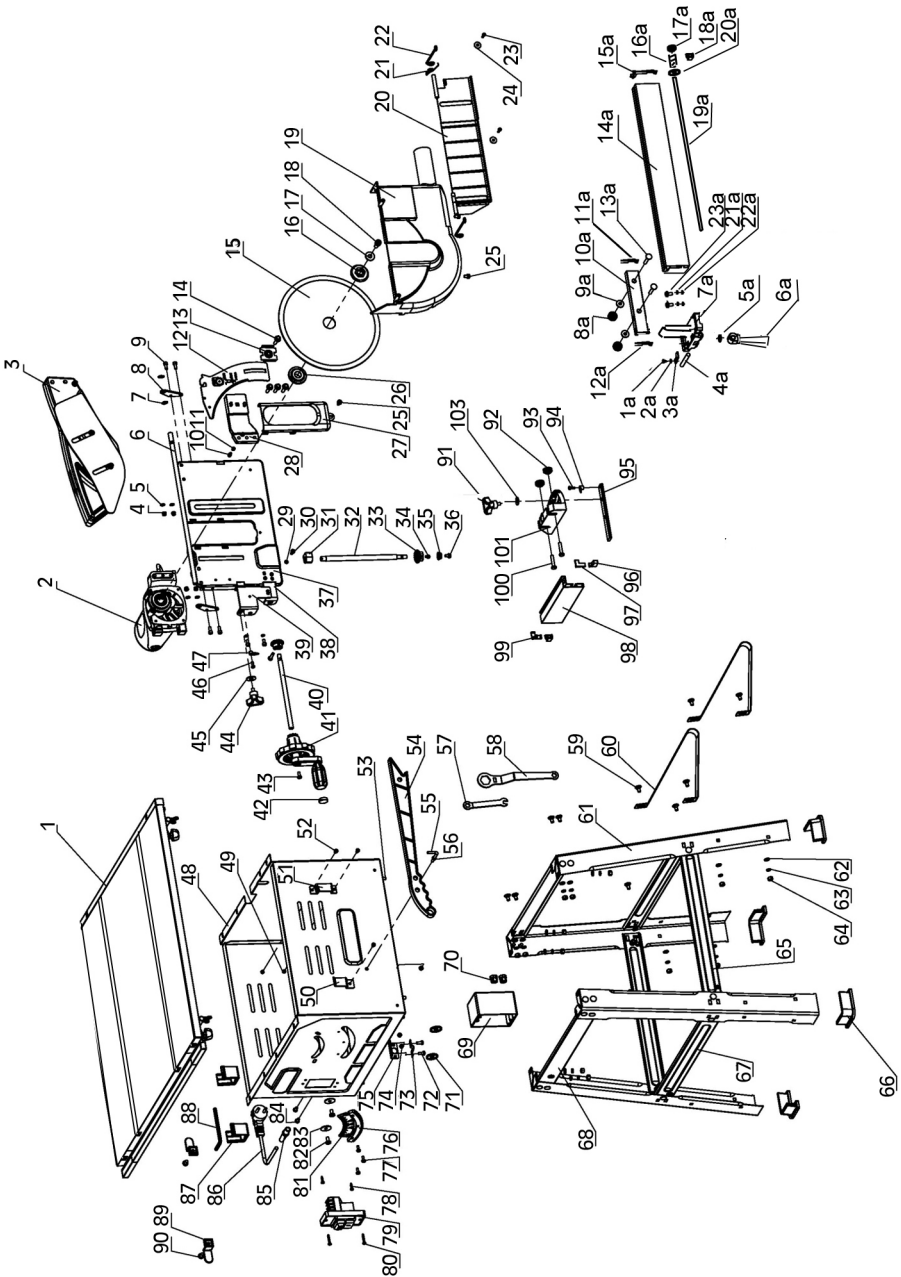



## PARTS LIST

No	Item	No	Item	No	Item
1	Work table assembly	31	Stop nut	61	Stand upright
2	Drive motor	32	Threaded rod	62	Flat washer
3	Blade guard	33	Bevel gear	63	Spring washer
4	Locknut	34	S/t screws	64	Nut
5	Washer	35	Screw rod sleeve	65	Short crossbar
6	Tilting frame	36	Screw, washer & nut	66	Rubber foot
7	Retaining ring	37	Drive Base plate	67	Long lower crossbar
8	Connection plate	38	Handwheel mount	68	Long upper crossbar
9	Socket headed bolt	39	Bracket	69	Switchbox
10	Brake column	40	Blade lifting shaft	70	Grommet
11	Brake spring	41	Blade lifting handle	71	Stop sleeve
12	Riving knife	42	Handle end cap	72	Screw
13	Retaining plate	43	Screw, washer & nut	73	Connecting sheet
14	Hex flange bolt	44	Angle locking knob	74	Nut
15	Saw blade	45	Washer	75	Right angle bracket
16	Outer retaining disc	46	Screw	76	Rack
17	Large washer	47	Pointer needle	77	Screw
18	Socket head screw	48	Machine casing	78	Screw
19	Lower guard	49	Nut	79	On/Off switch
20	Rotating stop plate	50	Open bracket	80	Screw
21	Torsion spring	51	Closed bracket	81	Angle degree label
22	Stop plate stand	52	Screw	82	Screw
23	S/t screw	53	Carriage bolt	83	Washer
24	Washer	54	Pushstick	84	Screw
25	Screw	55	Storage hook	85	Cable gland
26	Inner retaining disc	56	Nut	86	Power cable
27	Blade guard	57	Small spanner	87	Hook
28	Riving knife mount	58	Ring spanner	88	Hex key
29	Spring pad	59	Carriage bolt	89	Winding clip
30	Socket head screw	60	Support arm	90	Screw

91	Handle grip	95	Slide bar	99	End block-left
92	Thumbscrew	96	End block	100	Hex screw
93	Screw	97	Endcap-right	101	Mitre base
94	Pointer needle	98	Mitre fence		

### FENCE COMPONENTS SET A

No	Item	No	Item	No	Item
1a	Phillips s/t screw	9a	Flat washer	17a	Locknut
2a	Washer	10a	Side fence	18a	Clamp block
3a	Pointer	11a	Fence end cap LH	19a	Tie rod
4a	Roll pin	12a	Fence end cap RH	20a	Washer 4
5a	Washer	13a	Carriage bolt	21a	Flat washer
6a	Cam handle	14a	Guide fence	22a	Spring washer
7a	End casting	15a	Clamp arm	23a	Bolt
8a	Knob	16a	Spring		

### TABLE COMPONENTS SET B

No	Item	No	Item	No	Item
1b	Hex screw M6x30	12b	Locknut M6	23b	Left side plate
2b	Connect rod pad	13b	Phillips screw M6x20	24b	Right side plate
3b	Slide rod	14b	Hex screw M6x20	25b	Hex screw M5x14
4b	Washer 6	15b	Fixed sheet	26b	Hex screw M6x12
5b	Spring washer 6	16b	Hex screw M6x12	27b	Connecting sheet
6b	Wingnut M6	17b	Long fixing plate	28b	LH scale plate cover
7b	Fixing plate cover	18b	Hex screw M6x14	29b	Left scale plate
8b	Locknut M6	19b	Slide extend table	30b	Scale plate
9b	Short fixing plate	20b	Hex screw M6x12	31b	Right scale plate
10b	Triangular knob	21b	Table - right part	32b	RH scale plate cover
11b	Slide rod stand	22b	Table -left part	33b	Cover nut

## TABLE COMPONENTS SET B

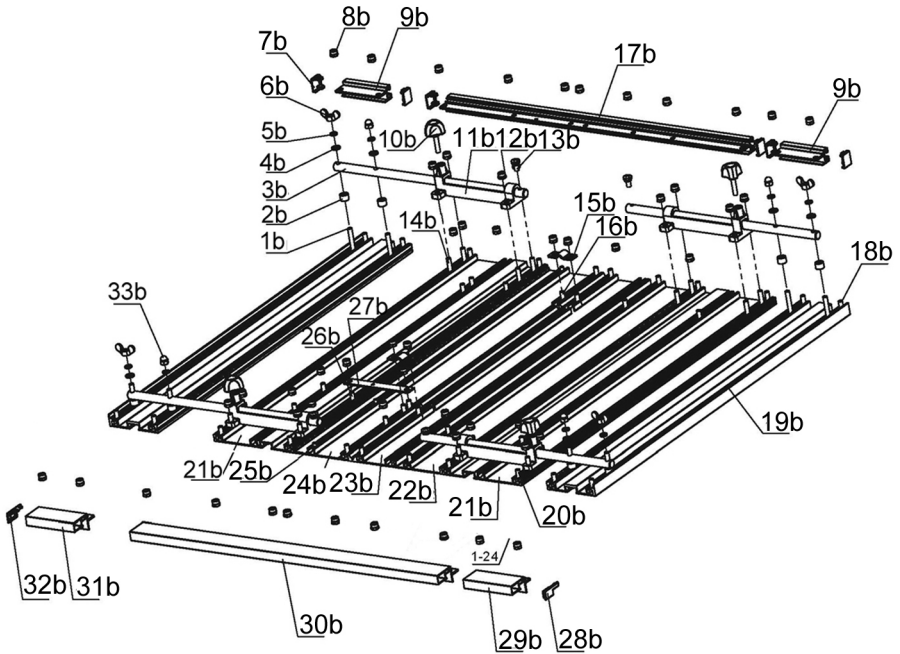

## USEFUL ITEMS FROM THE CLARKE CATALOGUE

Refer to the Clarke website [www.clarkeinternational.com](http://www.clarkeinternational.com) for a full range of items for use with this saw. See also the following accessories;

CARS1 Roller Stand	Part No: 6500980
CARS 3 in 1 Roller Stand	Part No: 6500983
CEWVE1 Vacuum Dust Extractor	Part No: 6471168
CVAC20P Vacuum Cleaner	Part No: 6471100

# A SELECTION FROM THE VAST RANGE OF

# Clarke®

## QUALITY PRODUCTS



### AIR COMPRESSORS

From DIY to industrial, Plus air tools, spray guns and accessories.

### GENERATORS

Prime duty or emergency standby for business, home and leisure.

### POWER WASHERS

Hot and cold, electric and engine driven - we have what you need

### WELDERS

Mig, Arc, Tig and Spot. From DIY to auto/industrial.

### METALWORKING

Drills, grinders and saws for DIY and professional use.

### WOODWORKING

Saws, sanders, lathes, mortisers and dust extraction.

### HYDRAULICS

Cranes, body repair kits, transmission jacks for all types of workshop use.

### WATER PUMPS

Submersible, electric and engine driven for DIY, agriculture and industry.

### POWER TOOLS

Angle grinders, cordless drill sets, saws and sanders.

### STARTERS/CHARGERS

All sizes for car and commercial use.

## PARTS & SERVICE:

## 0208 988 7400

### Parts Enquiries

[Parts@clarkeinternational.com](mailto:Parts@clarkeinternational.com)

### Servicing & Technical Enquiries

[Service@clarkeinternational.com](mailto:Service@clarkeinternational.com)

SALES: UK 01992 565333 or Export 00 44 (0)1992 565335

**Clarke** INTERNATIONAL Hemnall Street, Epping, Essex CM16 4LG  
[www.clarkeinternational.com](http://www.clarkeinternational.com)